

Leistritz

LEISTRITZ PUMPEN GMBH

Screw Pumps & Systems

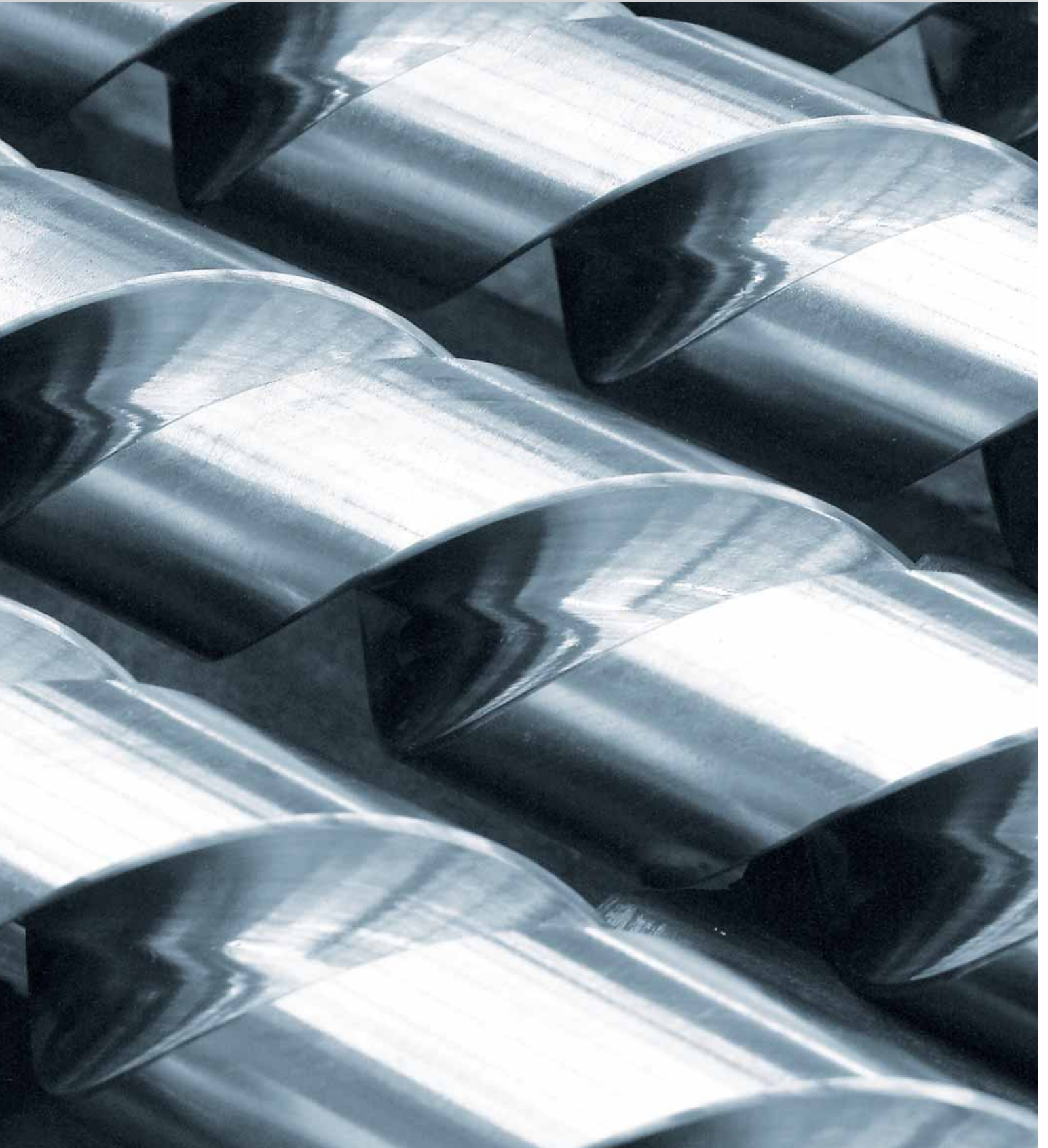



Markets & Industries

Leistriz Screw Pumps and Systems

Leistriz Pumpen GmbH, with its headquarters in Nuremberg/Germany, has been producing Screw Pumps since 1924. Latest Technology in combination with strictly controlled quality is the basis for the globally recognized Leistriz Product Efficiency and Reliability. With the widest range of Screw Pumps Leistriz serves all kind of markets and applications.



■ Oil & Gas



■ Commercial and Military Shipbuilding



■ Chemicals



■ Power Generation



■ Hydraulics



■ Pulp and Paper



■ Sugar



■ Steel



■ Textiles











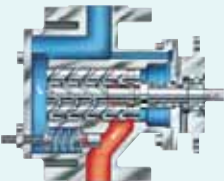
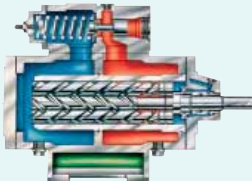





■ Paints



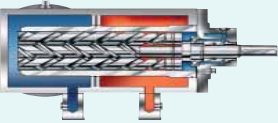

Leistritz Screw-Pump-Program

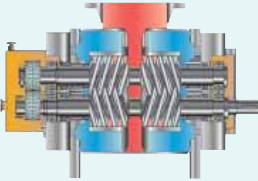
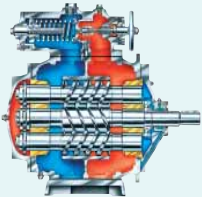
■ Leistritz Screw-Pump-Series:		L2	L3N	L3M
				
■ Oil & Gas		■	■	■
■ Commercial and Military Shipbuilding		■	■	■
■ Chemicals		■	■	■
■ Power Generation		■	■	■
■ Hydraulics				■
■ Pulp and Paper		■	■	■
■ Sugar		■	■	■
■ Steel		■	■	■
■ Textiles		■		■
■ Paints		■		■

L3H	L3V/U	L4	L5	LPS
				
■	■	■	■	■
■		■	■	■
■	■	■	■	■
■	■	■	■	■
■	■			
■				
■	■	■		
■	■	■		
■				
■				



Leistritz Screw-Pump-Program

L2-Series



L2NG

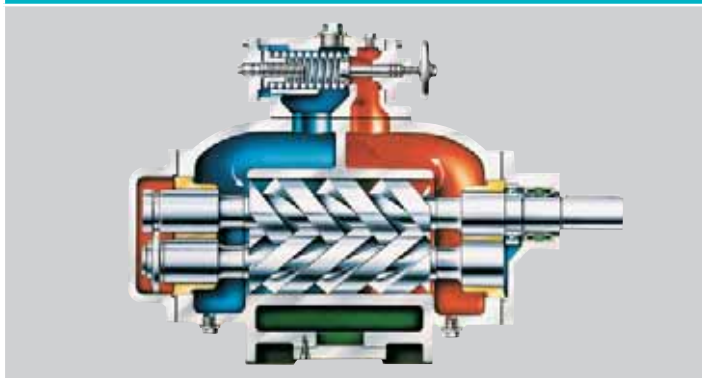

L2NT

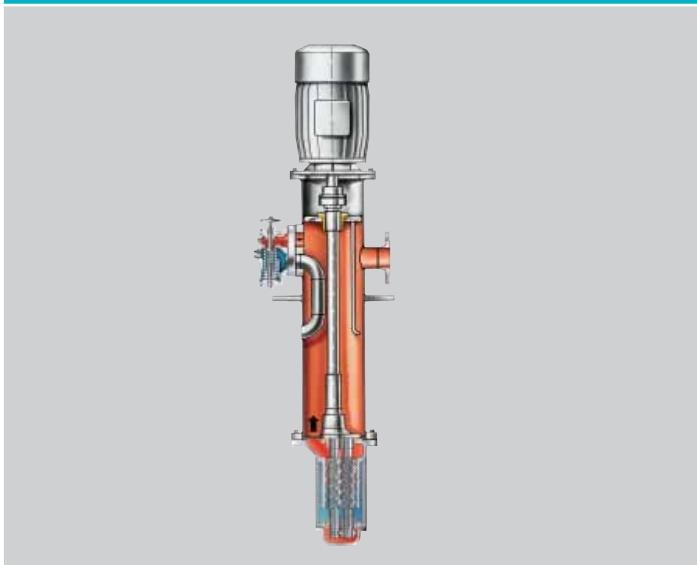

GENERAL USE

Leistritz Screw Pumps of series L2NG/NT are Twin Screw single volute, self-priming positive displacement pumps for low pressure duty, suitable for transport of light abrasive and corrosive, high or low viscous fluids with poor or good lubricity.

PERFORMANCE DATA

Capacity:	Max. 900 m ³ /h (3,960 GPM)
Differential Pressure:	Max. 16 bar (232 psi)
Viscosity:	Max. 100,000 cSt
Pumping Temperature:	Max. 280° C (536° F)

USER ADVANTAGES

- Radial Slight Bearings > Long Service Life
- High Efficiency > Low Operating Costs
- Axially Balanced Rotors > No Axial Forces to Bearings
- Low Axial Flow Velocity > Excellent Priming
- Only One Shaft Seal > Easy Maintenance, Low Costs
- Resistant Against Aeration > Low Noise, Minimized Vibration
- Dry Running Capability > Maximized Process Safety
- Availability of Sealless Design by Magnetic Drive
- Semi Submersible Pump Design Available

APPLICATION

Oil & Gas / Refineries

Use as unloading, stripping, circulating, transfer, blending or export pumps for fluids with poor and good lubricity, clean or slightly abrasive/corrosive fluids, low and high viscous fluids, e.g. lube oils, crude oils, fuel oils, bitumen, tar, asphalt, grease, residues, paraffin. Use as water turbines in fire-fighting systems.

Shipbuilding

Use as (main) lube oil-, transfer-, control-, hydraulic-, cooling/circulating-, fuel oil/diesel pumps for diesel engines, gas-turbines and gearboxes. Use as ship-loading/unloading pumps.

Chemicals

Use as unloading, stripping, circulating, transfer, blending or export pumps for fluids with poor and good lubricity, clean or slightly abrasive/corrosive fluids, low and high viscous fluids, e.g. additives, resins, grease, glue, adhesives, isocyanates, polyol, paints, polymers.

Power Generation and Fuel Oil Systems

Use as unloading and transfer pumps, charging pumps, for transport of heavy and light oils, pumps for all lubricating fluids.

Rotating and General Machinery

Use as lube oil, seal oil-, control oil-, hydraulic-, cooling/circulating-, fuel oil/diesel pumps for diesel engines, compressors, gas-, steam-, water turbines and gearboxes.

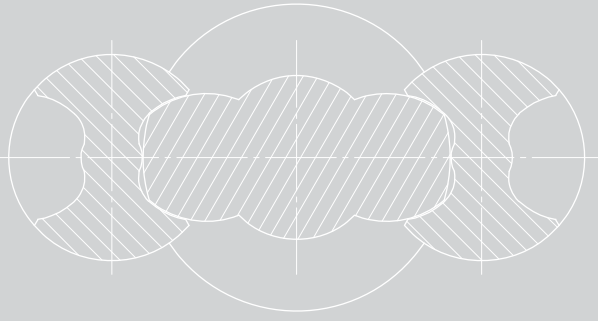

L3N-Series

L3NG

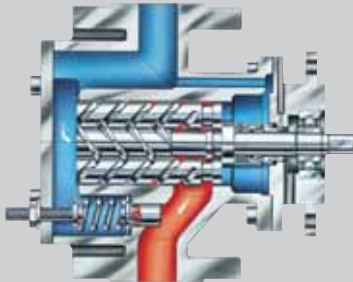

L3NT



GENERAL USE

Leistritz Screw Pumps of series L3NG/NT are Triple Screw single volute, self-priming positive displacement pumps for low pressure duty, suitable for transport of non abrasive lubricating fluids.

PERFORMANCE DATA

Capacity:	Max. 700 m ³ /h (3,100 GPM)
Differential Pressure:	Max. 16 bar (232 psi)
Viscosity:	Max. 15,000 cSt
Pumping Temperature:	Max. 180° C (356° F)

USER ADVANTAGES

- High Efficiency > Low Operating Costs
- Axially Balanced Rotors > No Axial Forces to Bearings
- Only One Shaft Seal > Easy Maintenance, Low Costs
- Availability of Sealless Design by Magnetic Drive
- Semi Submersible Pump Design Available
- Resistant Against Aeration > Low Noise, Minimized Vibration
- Simple Design > Reasonable Price

APPLICATION

Oil & Gas / Refineries

Use as transfer, circulating, blending or export pumps for all kind of clean, lubricating, low/high viscous fluids, e.g. lube oils, crude oils, fuel oils.

Shipbuilding

Use as (main) lube oil-, transfer-, control-, hydraulic-, cooling/circulating-, fuel oil/diesel pumps for diesel engines, gas-turbines and gearboxes.

Chemicals

Use as transfer, circulating, blending or export pumps for all kind of clean, lubricating, low/high viscous fluids, e.g. additives, resins, grease, glue, adhesives, isocyanats, polyol, paints.

Power Generation and Fuel Oil Systems

Use as transfer and charging pumps for transport of heavy and light oils, pumps for all lubricating fluids.

Rotating and General Machinery

Use as lube oil, control oil-, hydraulic-, cooling/circulating-, fuel oil/diesel pumps for diesel engines, compressors, gas-, steam-, water turbines and gearboxes.



Leistritz Screw-Pump-Program

L3M-Series

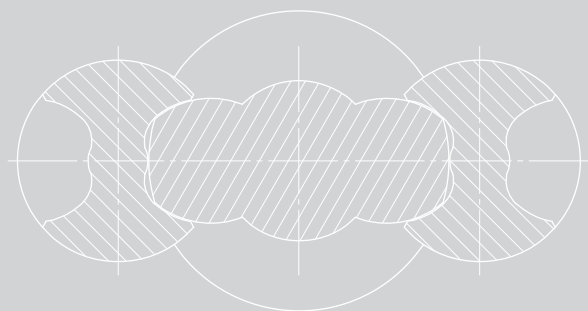

L3MF

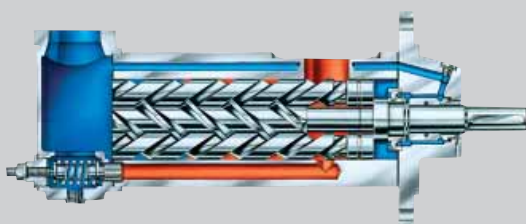

L3MG

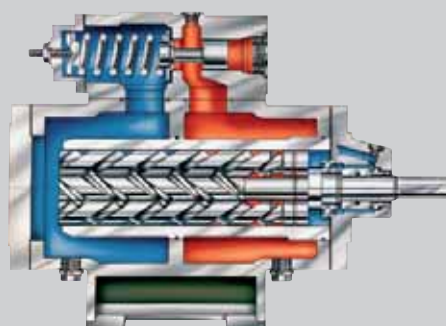

GENERAL USE

Leistritz Screw Pumps of series L3MF/MG are Triple Screw single volute, self-priming positive displacement pumps for medium pressure duty, suitable for transport of non abrasive lubricating fluids.

PERFORMANCE DATA

Capacity (L3MF):	Max. 120 m ³ /h (530 GPM)
Capacity (L3MG):	Max. 300 m ³ /h (1,320 GPM)
Differential Pressure:	Max. 80 bar (1,160 psi)
Viscosity:	Max. 10,000 cSt
Pumping Temperature:	Max. 280° C (536° F)

USER ADVANTAGES

- High Efficiency > Low Operating Costs
- Interchangeable Casing Insert (MG) > Easy Maintenance
- Axially Balanced Rotors > No Axial Forces to Bearings
- Only One Shaft Seal > Easy Maintenance, Low Costs
- Availability of Sealless Design by Magnetic Drive
- Semi Submersible Pump Design Available
- Resistant Against Aeration > Low Noise, Minimized Vibration
- Simple Design > Reasonable Price

APPLICATION

Oil & Gas / Refineries

Use as transfer, circulating, blending or export pumps for all kind of clean, lubricating, low/high viscous fluids, e.g. lube oils, crude oils, fuel oils, bitumen, grease, paraffin. Use as foam injection pumps in fire-fighting systems.

Shipbuilding

Use as lube oil-, transfer-, control-, hydraulic-, cooling/circulating-, fuel oil/diesel pumps for diesel engines, gas-turbines and gearboxes.

Chemicals

Use as transfer, circulating, blending or export pumps for all kind of clean, lubricating, low/high viscous fluids, e.g. additives, resins, grease, glue, adhesives, isocyanates, polyol, paints.

Power Generation and Fuel Oil Systems

Use as transfer and charging pumps, for transport of heavy and light oils, pumps for all lubricating fluids.

Rotating and General Machinery

Use as lube oil, control oil-, hydraulic-, cooling/circulating-, fuel oil/diesel pumps for diesel engines, compressors, gas-, steam-, water turbines and gearboxes.

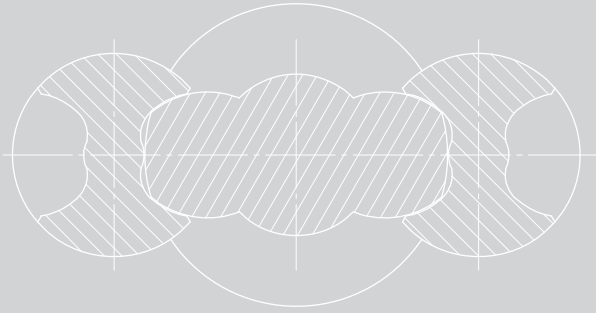

L3H-Series

L3HF

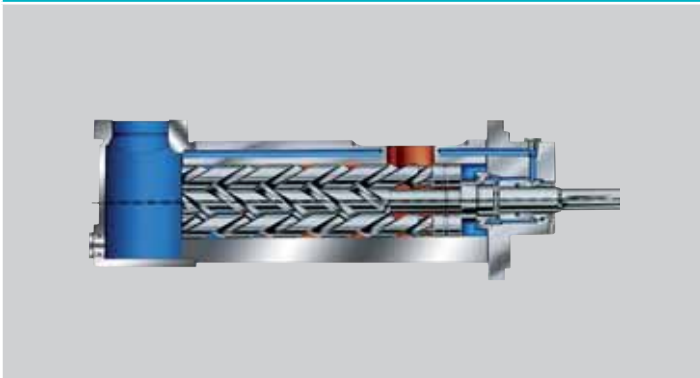

L3HG

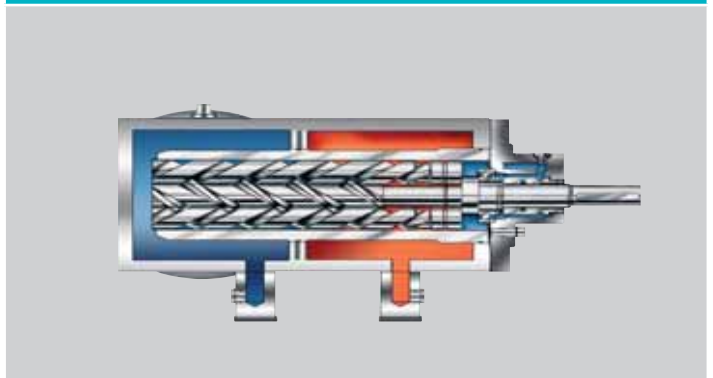

GENERAL USE

Leistritz Screw Pumps of series L3HF/HG are Triple Screw single volute, self-priming positive displacement pumps for high pressure duty, suitable for transport of non abrasive lubricating fluids.

PERFORMANCE DATA

Capacity (L3HF):	Max. 120 m ³ /h (530 GPM)
Capacity (L3HG):	Max. 200 m ³ /h (880 GPM)
Differential Pressure:	Max. 160 bar (2,320 psi)
Viscosity:	Max. 10,000 cSt
Pumping Temperature:	Max. 280° C (536° F)

USER ADVANTAGES

- High Efficiency > Low Operating Costs
- Interchangeable Casing Insert (HG) > Easy Maintenance
- Axially Balanced Rotors > No Axial Forces to Bearings
- Only One Shaft Seal > Easy Maintenance, Low Costs
- Availability of Sealless Design by Magnetic Drive
- Semi Submersible Pump Design Available
- Resistant Against Aeration > Low Noise, Minimized Vibration
- Simple Design > Reasonable Price

APPLICATION

Oil & Gas / Refineries

Use as transfer, circulating, blending or export pumps for all kind of clean, lubricating, low/high viscous fluids, e.g. lube oils, crude oils, fuel oils, bitumen, paraffin, grease.

Shipbuilding

Use as hydraulic pumps.

Chemicals

Use as transfer, circulating, blending or export pumps for all kind of clean, lubricating, low/high viscous fluids, e.g. additives, resins, grease, glue, adhesives, isocyanates, polyol, paints.

Power Generation and Fuel Oil Systems

Use as fuel oil injection, seal oil and jacking pumps.

Rotating and General Machinery

Use as fuel oil injection pumps for gas-turbines, seal oil pumps for compressors and gas-turbines, jacking pumps for steam-, water and gas-turbines, hydraulic pumps for presses.



Leistritz Screw-Pump-Program

L3V/U-Series

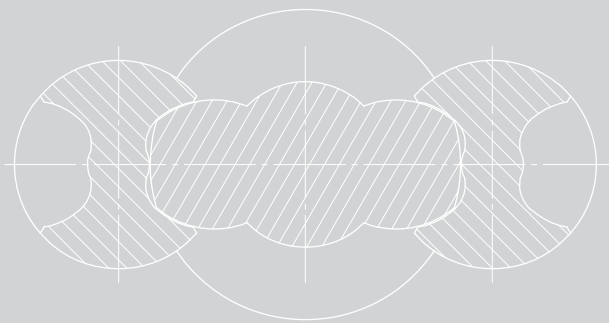

L3VF/UF

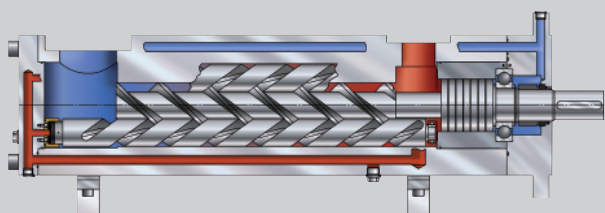

L3VG/UG

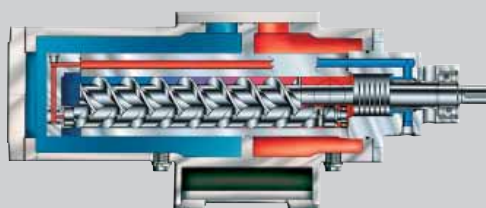

GENERAL USE

Leistritz Screw Pumps of series L3VF/UF (VG/UG) are Triple Screw single volute, self-priming positive displacement pumps for ultra high pressure duty suitable for transport of light abrasive and corrosive, high or low viscous fluids with poor or good lubricity.

PERFORMANCE DATA

Capacity:	Max. 180 m ³ /h (792 GPM)
Differential Press. (VF/VG):	Max. 200 bar (2,900 psi)
Differential Press. (UF/UG):	Max. 280 bar (4,060 psi)
Viscosity:	Max. 1,000 cSt
Pumping Temperature:	Max. 280° C (536° F)

USER ADVANTAGES

- High Efficiency > Low Operating Costs
- Interchangeable Casing Insert (VG/UG) > Easy Maintenance
- Wear Resistant Coatings Available
- Axially Balanced Rotors > No Axial Forces to Bearings
- Only One Shaft Seal > Easy Maintenance, Low Costs
- Availability of Sealless Design by Magnetic Drive
- Semi Submersible Pump Design Available
- Resistant Against Aeration > Low Noise, Minimized Vibration
- Simple Design > Reasonable Price

APPLICATION

Oil & Gas / Refineries

Use as transfer, circulating, blending or export pumps for clean, light abrasive or corrosive, high and low viscous fluids with poor and good lubricity, e.g. lube oils, crude oils, fuel oils, bitumen, asphalt, tar, kerosene, oil/water emulsions, residues, grease, paraffin. Use as crude oil booster pumps.

Shipbuilding

Use as hydraulic pumps.

Chemicals

Use as transfer, circulating, blending or export pumps for clean, light abrasive or corrosive, high and low viscous fluids with poor and good lubricity, e.g. additives, resins, grease, glue, adhesives, isocyanates, polyol, paints.

Power Generation and Fuel Oil Systems

Use as fuel oil injection, seal oil and jacking pumps.

Rotating and General Machinery

Use as fuel oil injection pumps for gas-turbines, seal oil pumps for compressors and gas-turbines, jacking pumps for steam-, water and gas-turbines, as hydraulic pumps for presses.

L4 -Series

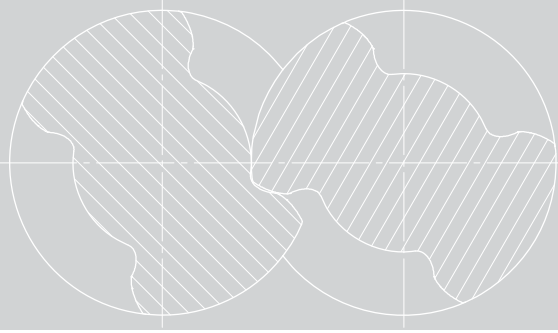

L4NG/MG

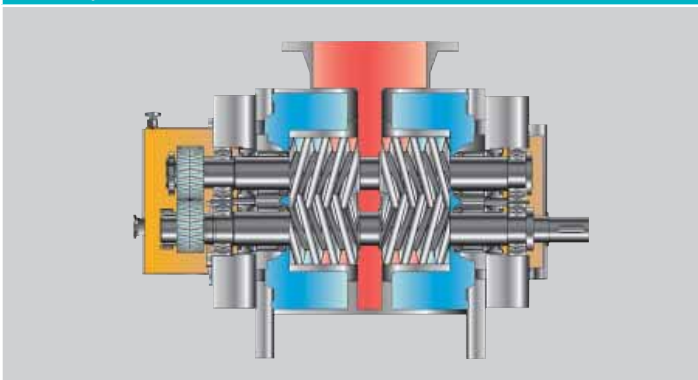

L4HG

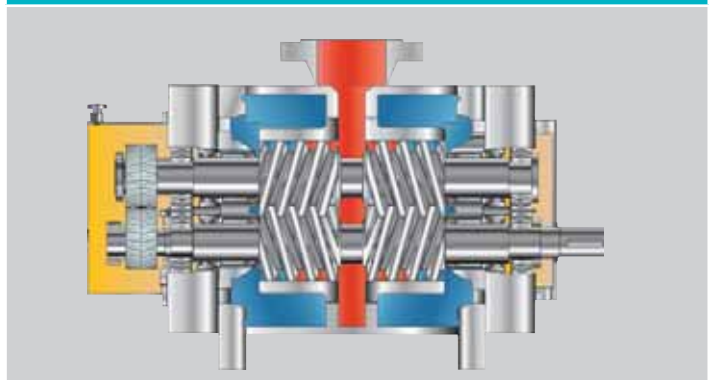

GENERAL USE

Leistritz Screw Pumps of series L4 are Twin Screw double volute, self-priming positive displacement pumps for low, medium and high pressure duty, suitable for transport of abrasive/non abrasive, corrosive/non corrosive, lubricating/non lubricating, high or low viscous fluids.

PERFORMANCE DATA

Capacity:	Max. 5,000 m ³ /h (22,000GPM)
Differential Pressure:	Max. 150 bar (2,175 psi)
Viscosity:	Max. 150,000 cSt
Pumping Temperature:	Max. 350° C (662° F)

USER ADVANTAGES

- Rotors (Screws and Shafts) Made out of a Single Piece of Bar Stock
 - > Limited Shaft Deflection
 - > Low Bearing Loads
- Maximum Allowable Rotor Deflection Limited to 50% of Radial Clearance between Rotor Housing and Rotor > Highest Process Safety
- Gear Designs with Helical Gear Teeth
 - > Reduced Noise Level
 - > Easy Maintenance
- Interchangeable Liner > Easy Maintenance, Low Costs
- Special Rotor Design Available
 - > Minimized Pulsation
 - > Optimized NPSHR
- Low Axial Flow Velocity > Excellent Priming
- Axially Balanced Rotors > No Axial Forces to Bearings
- Suitable for Dry Running > Maximized Process Safety

APPLICATION

Oil & Gas / Refineries

Use as pipeline start-up, unloading, tank cleaning, stripping, transfer and booster, circulating, blending and export pumps for all kinds of fluids, e.g. multiphase liquids, crude oils, produced water, crude oil/water emulsions, fuel oils, bitumen, tar, asphalt, grease, residues, paraffin, molten sulphur, kerosene, slops and drains.

Shipbuilding

Use as ship-loading and unloading pumps.

Chemicals

Use as unloading, tank cleaning, stripping, transfer, circulating, blending and export pumps for all kinds of fluids, e.g. additives, resins, grease, glue, adhesives, isocyanates, polyol, paints, acids, caustic solutions, rubber solutions, polymers.

Power Generation and Fuel Oil Systems

Use as unloading, transfer and charging pumps, for transport of heavy and light oils.



Leistritz Screw-Pump-Program

L5-Series

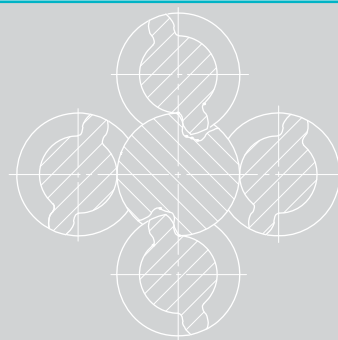

L5NG

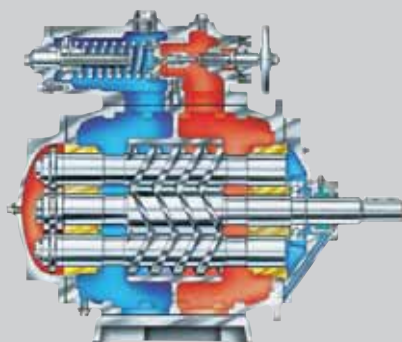

L5NT

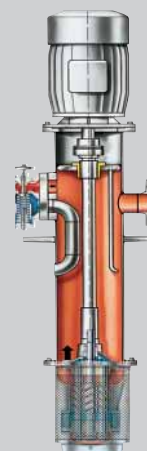

GENERAL USE

Leistritz Screw Pumps of series L5NG/NT are Five Screw single volute, self-priming positive displacement pumps for low pressure duty, suitable for transport of light abrasive and corrosive, high or low viscous fluids with poor or good lubricity.

PERFORMANCE DATA

Capacity:	Max. 1,700 m ³ /h (7,500 GPM)
Differential Pressure:	Max. 10 bar (145 psi)
Viscosity:	Max. 100,000 cSt
Pumping Temperature:	Max. 280° C (536° F)

USER ADVANTAGES

- High Efficiency > Low Operating Costs
- Radial Slight Bearings > Long Service Life
- Axially Balanced Rotors > No Axial Forces to Bearings
- Dry Running Capability > Maximized Process Safety
- Low Axial Flow Velocity > Excellent Priming
- Only One Shaft Seal > Easy Maintenance, Low Costs
- Resistant Against Aeration > Low Noise, Minimized Vibration
- Semi Submersible Pump Design Available

APPLICATION

Oil & Gas / Refineries

Use as unloading, stripping, transfer or export pumps for fluids with poor and good lubricity, clean or slightly abrasive/corrosive fluids, low and high viscous fluids, e.g. lube oils, crude oils, fuel oils, bitumen, tar, asphalt, grease, residues, paraffin. Use as water turbines in fire-fighting systems.

Shipbuilding

Use as main lube oil pump for diesel engines and as ship-loading/unloading pumps.

Chemicals

Use as unloading, stripping, transfer or export pumps for fluids with poor and good lubricity, clean or slightly abrasive/corrosive fluids, low and high viscous fluids, e.g. additives, resins, grease, glue, adhesive, isocyanates, polyol, paints.

Power Generation and Fuel Oil Systems

Use as unloading, transfer and charging pumps, for transport of heavy and light oils, pumps for all lubricating fluids.

Leistritz-Pump-Systems

Beside simple pump skids, consisting of Leistritz Screw Pumps, drivers and common baseplates, Leistritz supplies complete Pump Systems, suitable for various duties and applications.

These Pump Systems include variable speed drives, external lubrication systems, filtration systems, extended pipings with valves, various instrumentation- and control-systems, recirculation systems, cooling facilities, and fire-fighting systems.

Leistritz Pump Systems are particularly used for Crude Oil Boosting or Multiphase Application.





Leistritz Screw-Pump-Program

Pump-Inquiry-Form

Customer Data	
Date:	Contact Person:
Company:	E-Mail:
Street:	Phone:
Post Code:	Fax:
City:	Project Name:
Project-Classification	
Number of Pumps: <input type="checkbox"/> 1 <input type="checkbox"/> 2 <input type="checkbox"/> 3 <input type="checkbox"/> 4 <input type="checkbox"/> ____	Required Delivery Date:
Market: <input type="checkbox"/> Oil & Gas <input type="checkbox"/> Chemicals <input type="checkbox"/> Power Generation <input type="checkbox"/> Shipbuilding <input type="checkbox"/> Textiles	
<input type="checkbox"/> Hydraulics <input type="checkbox"/> Steel <input type="checkbox"/> Sugar <input type="checkbox"/> Paints	
<input type="checkbox"/> Other: _____	
Leistritz Pump Scope of Supply/Accessories	
<input type="checkbox"/> Pump <input type="checkbox"/> Internal/Top Mounted Safety Valve <input type="checkbox"/> External API Safety Valve	
<input type="checkbox"/> Baseplate <input type="checkbox"/> Coupling <input type="checkbox"/> Coupling Guard <input type="checkbox"/> Drive	
<input type="checkbox"/> Frequency Inverter <input type="checkbox"/> Counter Flanges <input type="checkbox"/> Mano-/Vaccumeter <input type="checkbox"/> Commissioning Spares	
<input type="checkbox"/> 2Years Operation Spares <input type="checkbox"/> Other _____	
Product Specification	
Fluid:	
Density: _____ Kg/m ³	
Operating Temperature: min: _____ normal: _____ max: _____ °C/°F	
Viscosity at Operat. Temp.: min: _____ normal: _____ max: _____ cst	
Solid Content: _____ % (weight/volume) Solid Size min/max: _____ mm	
Characteristics of Solids: <input type="checkbox"/> soft <input type="checkbox"/> hard	
Operating Data	
Capacity: min: _____ normal: _____ max: _____ <input type="checkbox"/> l/min <input type="checkbox"/> m ³ /h <input type="checkbox"/> US GPM	
Discharge Pressure: min: _____ normal: _____ max: _____ <input type="checkbox"/> bar (g) <input type="checkbox"/> psi (g)	
Suction Pressure: min: _____ normal: _____ max: _____ <input type="checkbox"/> bar (g) <input type="checkbox"/> psi (g)	
Differential Pressure: min: _____ normal: _____ max: _____ <input type="checkbox"/> bar (g) <input type="checkbox"/> psi (g)	
NPSHA: _____ mwc	
Operation: <input type="checkbox"/> continous <input type="checkbox"/> discontinous _____ hrs/day	

Pump-Inquiry-Form

Drive

E-Motor
 Steam Turbine
 Reduction Gear
 Others _____

Continous Speed _____ Variable Speed _____

Voltage: _____ V Frequency: _____ Hz
 Insulation Class _____
 Enclose IP _____

Zone: Hazardous Non-Hazardous

Hazardous: EExn
 EExe II T3
 EExd II BT4
 Other _____

Pump Execution

Shaft Sealing: Stuffing Box
 Mechanical Seal: single double

Radial Lip Seals
 Magnetic Coupling (Sealless)

Installation: Horizontal
 Vertical
 Flanged
 Submerged

Flange Position: Supplier Standard

Other, see below

NR side by side, right

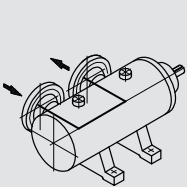

NO side by side, top

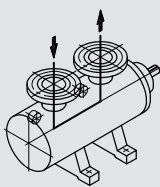

NL side by side, left

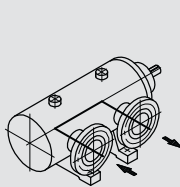

RRO rectangular right to top

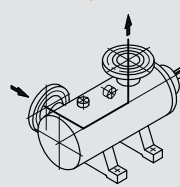

VRL offset right to left

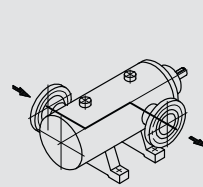

ROL rectangular top to left

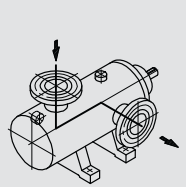

ROR rectangular top to right

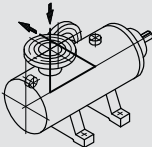

VLR offset left to right

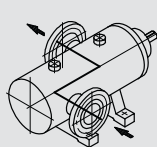

RLO rectangular left to top

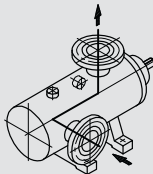

RER rectangular end to right

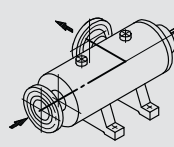

REO rectangular end to top

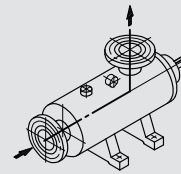

REL rectangular end to left

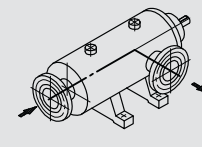

Applicable Standards

DIN/EN
 API 676
 API 614
 Other _____

Remarks



Leistriz

Product Range



LEISTRITZ TURBOMASCHINEN TECHNIK GMBH
LEISTRITZ TURBINENKOMPONENTEN REMSCHEID GMBH
LEISTRITZ ADVANCED TURBINE COMPONENTS, INC.
Blades, Disks and Components for Turbines and Compressors



LEISTRITZ PUMPEN GMBH
Screw Pumps and Systems

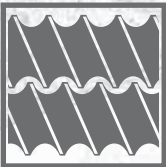

LEISTRITZ EXTRUSIONSTECHNIK GMBH
Extruders



LEISTRITZ PRODUKTIONSTECHNIK GMBH
Tubing Technology/Sheet Metal Forming, Machine Tools, Tools
Profile Rolling Machines and Rolling Tools



■ Headquarter Nuernberg:
LEISTRITZ PUMPEN GMBH
Markgrafenstrasse 29-39
D-90459 Nuernberg
Germany
Phone: +49 (0)911/4306 - 0
Fax: +49 (0)911/4306 - 490
E-Mail: pumpen@leistriz.com
www.leistriz.com

● LEISTRITZ ITALIA SRL
Via dei Fontanili, 26
I-20141 Milan
Italy
Phone: +39 02 84477 451
+39 02 84477 505
Fax: +39 02 84477 444
E-Mail: pompeitalia@leistriz.com

▲ LEISTRITZ CORPORATION USA
165 Chestnut Street
USA-Allendale, NJ 07401
USA
Phone: +1 201/934 8262
Fax: +1 201/934 8266
E-Mail: staff@leistrizcorp.com